

FireBall™

INSTALLATION INSTRUCTIONS for XR700 and XR3000 OPTICALLY TRIGGERED IGNITION SYSTEM

Part Numbers 700-0226, 700-0231, 700-0292, 700-0300, 700-0309, 700-6231, 720-0231, 3000-0226, 3000-0231, 3000-0292

CAUTION: READ INSTRUCTIONS CAREFULLY BEFORE STARTING INSTALLATION.

OVERVIEW

XR700 and XR3000 electronic ignition modules use an optical trigger assembly to replace conventional breaker points and original equipment (OE) magnetic and Hall Effect pickup systems. The XR700 requires ballast resistance to limit coil current. The XR3000 is a high performance version with a computer chip that controls coil current and dwell. When installing an XR3000, all OE ballast resistance must be bypassed.

Read the following Introductory sections and then use the Optical Trigger Installation Index on page 2 to find the appropriate section for your vehicle.

IGNITION INSPECTION

The XR700/XR3000 optical trigger assembly requires an OE specification distributor cap and rotor to avoid clearance problems and arcing. You should replace the rotor and cap when installing the new ignition system. For best results, you should also replace the spark plugs, spark plug wires, and ignition coil. Carefully inspect wiring to the

Lucas only. Examine the distributor. Remove the cap and rotor. If your Lucas pickup is held down by two studs, you do not have an OPUS system and you must use Crane HI6500 module part number 6500-0043 instead.

coil and replace any worn or frayed sections. For maximum performance, use Crane coils and FireWire spark plug wires.

DISTRIBUTOR ALIGNMENT AND DISASSEMBLY

CAUTION: Disconnect the vehicle's battery ground cable before continuing installation.

1. Make notes and label all spark plug wires so that you can later re-install them. Remove distributor cap.
2. Part numbers 700-0226, 700-0309, and 3000-0226, skip ahead to step 6. Italian applications with Marelli distributor, skip remainder of this section and proceed to Optical Trigger Installation section.
3. Mark distributor below number one spark plug terminal as shown in Figure 1. Remove distributor cap. Crank engine and note direction of distributor shaft rotation.

Figure 1. Distributor Marking



4. Align engine timing marks as specified in shop manual. If rotor is pointing opposite direction from mark, rotate engine one more complete revolution and align timing marks again. Timing marks must remain aligned throughout the installation process.
5. Verify that rotor tip now points to the mark as shown in Figure 2. If not, loosen distributor tie down bolt and rotate distributor to align rotor tip to mark. Remember to tighten bolt when done. Note: Removal of distributor is not required, but may improve access. Follow instructions in shop manual. Mark engine where rotor tip is pointing. Do not crank engine with distributor removed.

Figure 2. Rotor Alignment

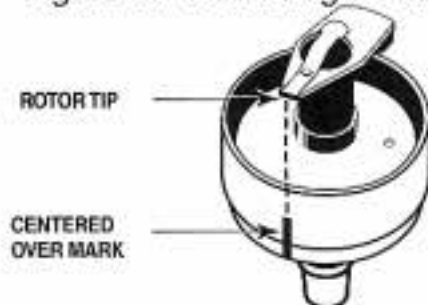

CRANE
Cams
The Leader in Performance Technology

530 Fentress Boulevard, Daytona Beach, FL 32114

Tech Line: (904) 258-6174

Fax: (904) 258-6167

Check our web site for updates: www.cranecams.com

- Remove rotor and plastic dust shield (if used). Breaker point applications: remove breaker points, breaker post/stud, condenser, and any wires from breaker points to coil or ground.

Do not damage rubber grommet through which wire exits distributor. **Bosch, Hitachi, Lucas, and Nippondenso OE electronic systems:** refer to detailed instructions in Optical Trigger Installation section.

CAUTION: Make sure you have read the introductory material and performed the distributor alignment and disassembly step before proceeding with optical trigger installation.

OPTICAL TRIGGER INSTALLATION INDEX

Part Numbers 700-0226 and 3000-0226:

Domestic 4-6-8 Cylinder (exc. Delco Remy 8 Cyl.) and VW with Bosch "009" Distributor	Page 2
Delco Remy 8 Cylinder	Page 3

Part Numbers 700-0231, 700-6231, 720-0231, and 3000-0231:

Universal 4-6-8 Cylinder (exc. Marelli)	Page 3
Marelli	Page 4

Part Numbers 700-0292 and 3000-0292:

Bosch Hall Effect	Page 5
Bosch Magnetic	Page 5
Hitachi	Page 6
Nippondenso	Page 7

Part Number 700-0300:

Lucas Opus	Page 7
------------------	--------

Part Number 700-0309:

Mallory YL Dual Point	Page 9
Mallory UniLite	Page 9

OPTICAL TRIGGER INSTALLATION

DOMESTIC 4-6-8 CYLINDER (EXCEPT DELCO-REMY 8 CYL) AND VW WITH BOSCH "009" DISTRIBUTOR

- Refer to Figure 3. Select the best fitting mounting bracket and install it on the distributor plate in the exact location where the points were mounted. Use the screws that held the points.
- Select the best fitting shutter with the same number of slots as cylinders for your application. Install shutter on distributor shaft cam. Make sure that the flats inside shutter line up with the cam flats. Use a socket to press the shutter down into position. To prevent breaking the shutter, do not press on the slotted rim.

Figure 3. Distributor Assembly

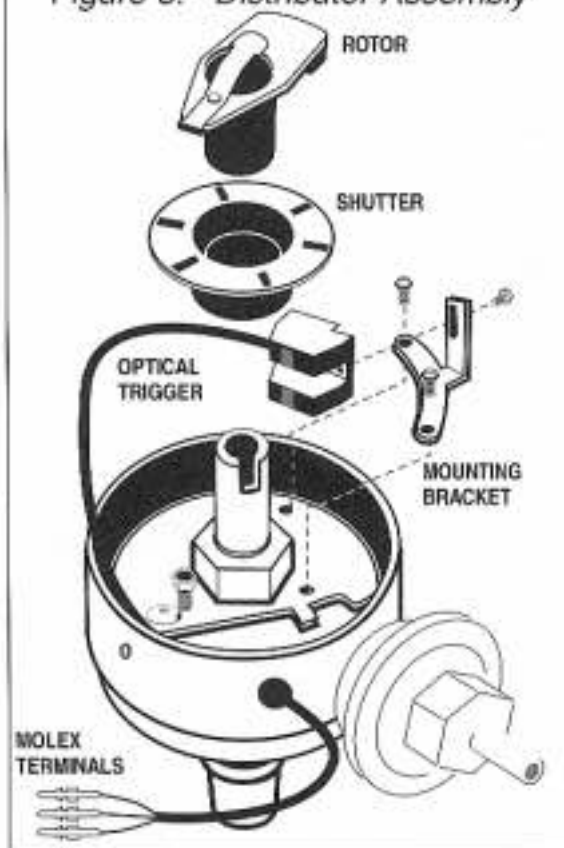
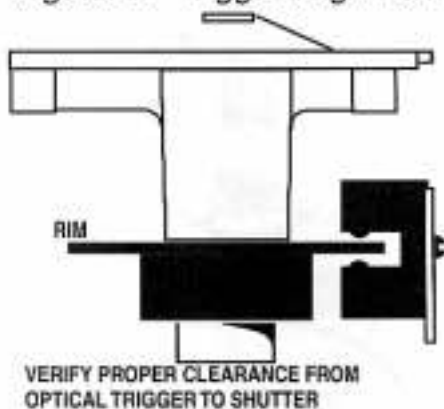

Figure 4. Trigger Alignment



3. Attach the optical trigger to the mounting bracket with the supplied 4-40 x 3/16" screw. Do not over tighten this screw. Adjust the trigger height so that the shutter rim is approximately in the middle of the trigger opening as shown in Figure 4. Check for clearance around all parts. Verify that the shutter is level and does not rub or touch. If required, readjust it. Reinstall rotor.
4. Pass optical trigger cable through exit hole used for the points wire. Attach cable to breaker plate with a nylon tie wrap. Leave enough slack to allow movement of vacuum advance mechanism. If possible use the original rubber grommet to seal the cable exit hole. Otherwise, use silicone sealer to seal wire exit hole.
5. Proceed with ignition module installation on page 10.

DELCO-REMY 8 CYLINDER DISTRIBUTOR

1. Refer to Figure 5. Use the supplied hardware. Attach the optical trigger to the mounting bracket with a 4-40 x 3/16" screw. Do not over tighten. Install the mounting bracket and the optical trigger on the distributor breaker plate at the points location using two 8-32 x 3/8" buttonhead screws and 1/8" spacers as shown.

2. Pass the shutter over the advance weights as shown in Figure 5. Position the shutter with the shutter rim underneath the advance weight plate. Align the shutter mounting holes with the rotor mounting holes in the advance weight plate.
3. Reinstall the rotor onto the advance weight plate in the original position as shown in Figure 6. Check for correct seating of rotor. Use the two supplied 10-32 x 7/8" screws as shown to secure the rotor and shutter. Firmly tighten these screws. Then check for proper shutter clearance as shown in Figure 7.
4. Pass optical trigger cable through exit hole used for the points wire. Attach cable to breaker plate with a nylon tie wrap. Leave enough slack to allow movement of vacuum advance mechanism. If possible, use the original rubber grommet to seal the cable exit hole. Otherwise, use silicone sealer to seal wire exit hole.
5. Proceed with ignition module installation on page 10.

UNIVERSAL 4-6-8 CYLINDER DISTRIBUTOR (ADJUSTABLE BRACKET KIT)

1. Attach mounting arm to optical trigger with supplied 4-40 x 3/16" screw as shown in Figure 8. To allow vertical adjustment of optical trigger, do not tighten screw completely.
2. Use an existing screw on the breaker plate to install the best fitting mounting foot as shown in Figure 8.

Figure 5. Delco-Remy Shutter

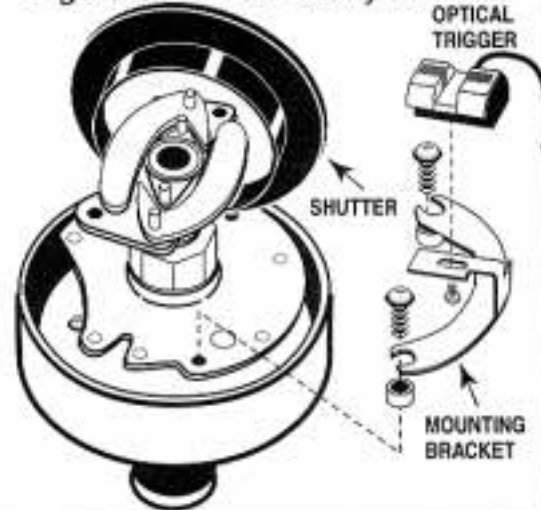

Figure 6. Delco-Remy Assembly

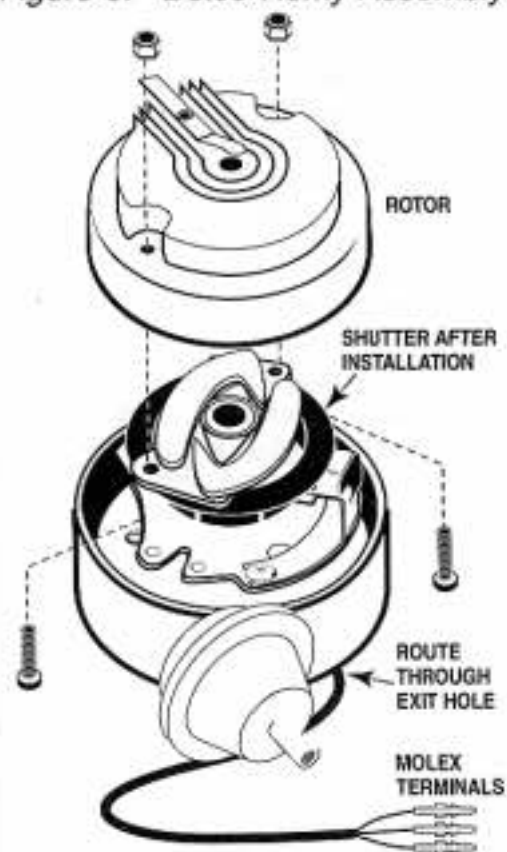

Figure 7. Trigger Alignment

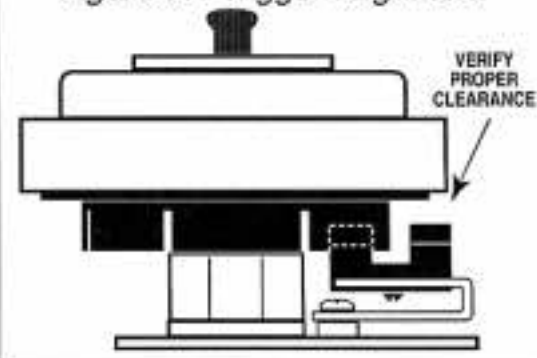
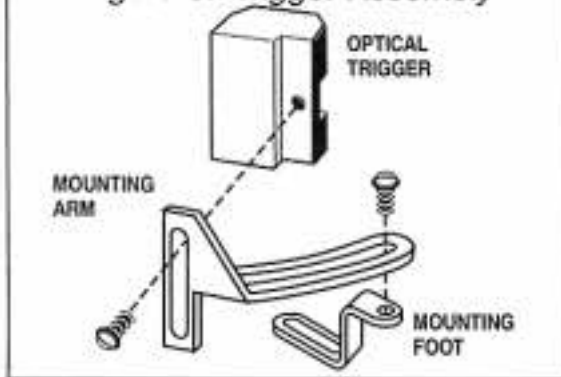

Figure 8. Trigger Assembly



To allow adjustment, do not tighten screw completely.

3. Select the best fitting shutter with the same number of slots as cylinders for your application. Use #220 shutter for four cylinder Bosch distributor. Slide it onto the distributor shaft cam until firmly seated and level. Make sure that the flats or springs inside shutter line up with the flats on the distributor cam. Use a socket to press the shutter down into position. To prevent breaking the shutter, do not press on the slotted rim.
4. Mount the optical trigger and bracket as shown in Figure 9. If clearance is limited, install shutter and optical trigger assembly together. Either side of the mounting arm can face up. Some applications may require attaching the mounting arm directly to the points plate, drilling and tapping a new hole in the points plate, and cutting or trimming the mounting arm or points plate. Attach mounting arm to mounting foot with supplied 6-32 x 3/16" screw as shown in Figures 8 and 9. To allow adjustment, do not tighten the screw completely. Pass optical trigger cable through exit hole used for the points wire.
5. **MG TC/TD only:** cut points plate at capacitor recess. Install trigger in recess area. Trim mounting arm. Do not use foot.
6. Adjust the optical trigger height so that the shutter rim is approximately in the middle of the trigger opening as shown in

Figure 4. Check for clearance around all parts. Verify that the shutter is level and does not rub or touch. If required, readjust it. Reinstall rotor.

7. Proceed with ignition module installation on page 10.

MARELLI DISTRIBUTOR

1. Set engine to TDC and mark distributor body where rotor tip is pointing. Remove distributor from engine.
2. Mark drive dog and distributor body so that it can be returned to the same position on re-assembly.
3. Remove spring, locating pin, shims, and sealing washer from drive dog. Remove distributor shaft from body.
4. Attach mounting arm to optical trigger with supplied 4-40 x 3/16" screw as shown in Figure 8. To allow vertical adjustment of optical trigger, do not tighten screw completely.
5. Use an existing screw on the breaker plate to install the best fitting mounting foot as shown in Figures 8 and 9. To allow adjustment, do not tighten screw completely.
6. Select the best fitting shutter with the same number of slots as cylinders for your application. Slide it onto the distributor shaft cam until firmly seated and level. Make sure that the flats or springs inside shutter line up with the flats on the distributor cam. Use a socket to press the shutter down into position. To prevent breaking the shutter, do not press on the slotted rim. If the shutter is a loose fit when you slide it onto the points cam, apply several drops of Super Glue.
7. Reassemble the distributor in reverse order of step 3.

Figure 9. Distributor Assembly

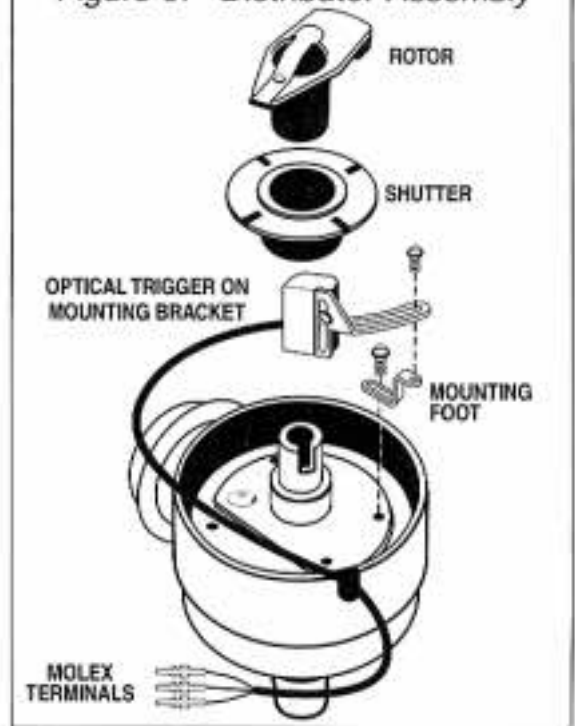

8. Mount the optical trigger and bracket as shown in Figure 9. If clearance is limited, install shutter and optical trigger assembly together. Either side of the mounting arm can face upwards to create the proper alignment with the shutter. Some applications may require attaching the mounting arm directly to the points plate, drilling and tapping a new hole in the points plate, and cutting or trimming the mounting arm or points plate to create the required clearance. Attach mounting arm to mounting foot with supplied 6-32 x 3/16" screw as shown in Figures 8 and 9. To allow adjustment, do not tighten the screw completely. Pass optical trigger cable through exit hole used for the points wire.
9. Adjust the optical trigger height so that the shutter rim is approximately in the middle of the trigger opening as shown in Figure 4. Check for clearance around all parts. Verify that the shutter is level and does not rub or touch. If required, readjust it. Reinstall rotor.

Figure 10. Bosch Hall Effect

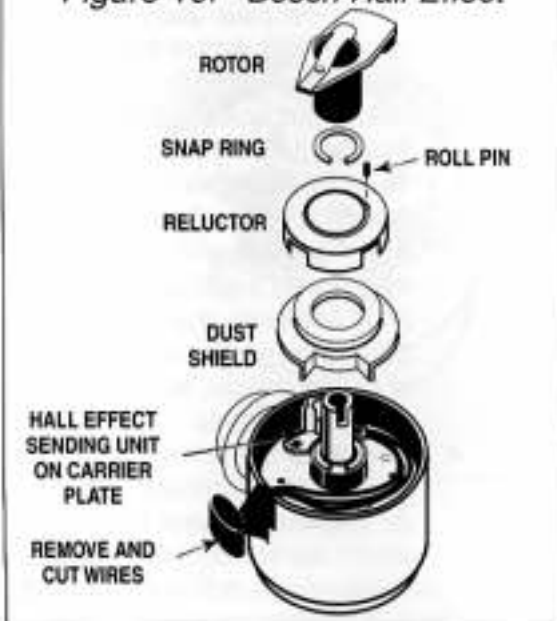

10. Reinstall distributor onto engine. Make sure you align the marks you made in steps 1 and 2.
11. Proceed with ignition module installation on page 10.

BOSCH HALL EFFECT DISTRIBUTOR

1. Refer to Figure 10. Remove snap ring and washer used to retain reluctor. Remove reluctor. Pry reluctor up using two screwdrivers as shown in Figure 11. Pull up and remove Hall effect connector from distributor housing. Pry off cable tie-down from carrier plate. Removal of Hall effect sending unit is not required, but you should cut the lead wires.
2. Select a vacant screw hole on the carrier plate away from obstructions. Refer to Figures 8 and 9 for orientation. Install the large mounting foot. If possible, select a threaded hole and use an original screw. Otherwise, use the supplied 3/16" self tapping screw. To allow adjustment, do not tighten screw completely.
3. Attach mounting arm to optical trigger with supplied 4-40 x 3/16"

screw as shown in Figure 8. To allow vertical adjustment of optical trigger, do not tighten screw completely.

4. Shutters for Bosch applications have a small "V" groove that matches the distributor shaft. Select a shutter with the same number of slots as cylinders for your application. Slide shutter onto the distributor shaft until firmly seated and level. You can use the rotor or a large socket as a tool to press the shutter down.
5. Mount the optical trigger and bracket as shown in Figure 9. If clearance is limited, install shutter and optical trigger assembly at the same time. Either side of the mounting arm can face upwards to create the proper alignment with the shutter. Attach mounting arm to mounting foot with supplied 6-32 x 3/16" screw as shown in Figures 8 and 9. To allow adjustment, do not tighten the screw completely.
6. Pass optical trigger cable through exit hole used for the OE pickup. If possible, use the original rubber grommet to seal the cable exit hole.
7. Adjust the optical trigger height so that the shutter rim is approximately in the middle of the trigger opening as shown in Figure 4. Check for clearance around all parts. Verify that the shutter is level and does not rub or touch. If required, readjust it. Reinstall rotor.
8. If distributor was removed, reinstall it. Align rotor tip with mark on engine. Then rotate distributor to align mark on distributor with rotor tip.
9. Proceed with ignition module installation on page 10.

Figure 11. Removal Procedure

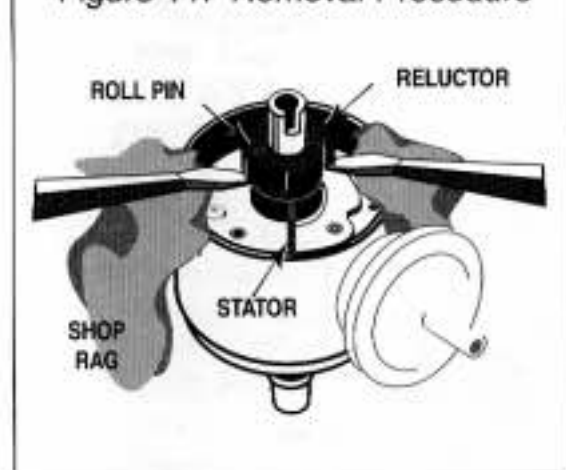

BOSCH MAGNETIC DISTRIBUTOR

1. Refer to Figure 12. Remove snap ring and washer used to retain reluctor. Remove reluctor. Pull reluctor straight up or pry up using two screwdrivers as shown in Figure 11. Remove second snap ring retaining magnetic pickup. Remove magnetic pickup. Remove screws holding carrier plate, stator, and vacuum advance mechanism. Note screw lengths and locations for future reassembly. Remove snap ring and washer retaining stator and carrier plate. Remove stator and carrier plate from distributor. Remove stator from carrier plate (held by three screws from bottom of carrier plate).
2. Reinstall carrier plate, vacuum advance mechanism, distributor cap retaining clips, and screws holding carrier plate to distributor body. Attach the small mounting foot to the top of stator (side with fingers) using the supplied 6-32 x 1/2" screw. Insert the screw through a hollow rivet from the bottom of stator and use a washer and nut on top. Refer to Figures 8 and 9 for orientation. To allow adjustment, do not tighten nut completely.

Figure 12. Bosch Magnetic

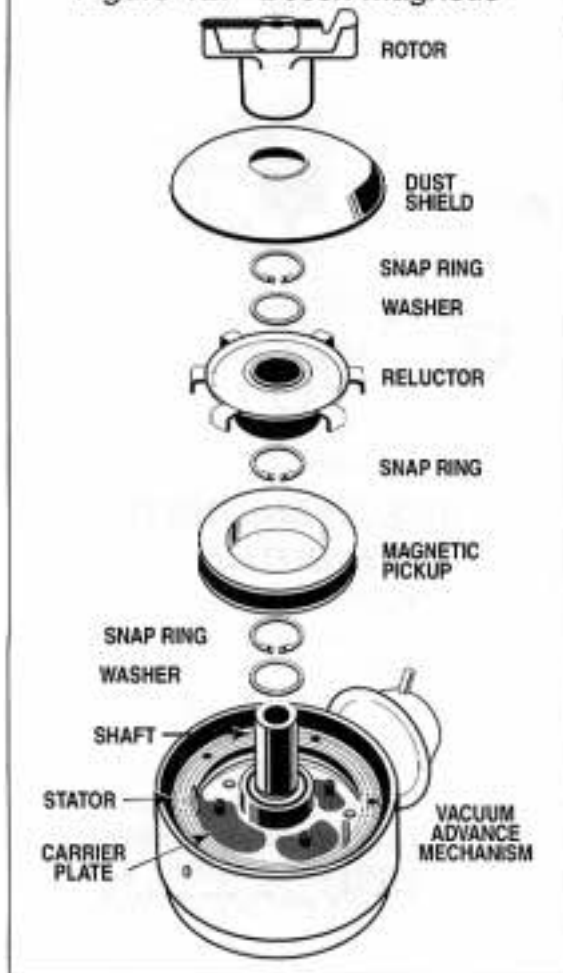

3. Reinstall stator. Rotate stator so pin on bottom of stator mates with hole on arm from vacuum advance mechanism. Reinstall washer and snap ring in original groove on distributor shaft above stator.
4. Attach mounting arm to optical trigger with supplied 4-40 x 3/16" screw as shown in Figure 8. To allow vertical adjustment of optical trigger, do not tighten screw completely.
5. Select the best fitting shutter with the same number of slots as cylinders for your application. Slide shutter onto the distributor shaft until firmly seated and level. Make sure that the keyway inside the shutter lines up with the distributor shaft. You can use the rotor or a large socket as a tool to press the shutter down.

6. Mount the optical trigger and bracket as shown in Figure 9. If clearance is limited, install shutter and optical trigger assembly at the same time. Either side of the mounting arm can face upwards to create the proper alignment with the shutter. Attach mounting arm to mounting foot with supplied 6-32 x 3/16" screw as shown in Figures 8 and 9. To allow adjustment, do not tighten the screw completely.
7. Pass optical trigger cable through exit hole used for the OE pickup. If possible, use the original rubber grommet to seal the cable exit hole.
8. Adjust the optical trigger height so that the shutter rim is approximately in the middle of the trigger opening as shown in Figure 4. Check for clearance around all parts. Verify that the shutter is level and does not rub or touch. If required, readjust it. Reinstall rotor.
9. If distributor was removed, reinstall it. Align rotor tip with mark on engine. Then rotate distributor to align mark on distributor with rotor tip.
10. Proceed with ignition module installation on page 10.

HITACHI DISTRIBUTOR

1. Remove three screws holding stator and remove stator. Remove magnetic ring, pickup coil, and pickup coil lead wires. Remove cup surrounding the pickup coil if cup is held by screws. Keep screws for later use. Do not attempt to remove cup if cup is held by rivets. Remove reluctor by prying up using two screwdrivers as shown in Figure 11. If cup could not be removed, skip to step 3.

2. Select a vacant screw hole on the carrier plate away from obstructions. Install the mounting foot using one of the original pickup coil screws. Refer to Figures 8 and 9 for orientation. To allow adjustment, do not tighten screw completely.
3. Attach mounting arm to optical trigger with supplied 4-40 x 3/16" screw as shown in Figure 8. To allow vertical adjustment of optical trigger, do not tighten screw completely.
4. Select the best fitting shutter with the same number of slots as cylinders for your application. Slide shutter onto the distributor shaft until firmly seated and level. Make sure that the flat inside the shutter lines up with the distributor shaft. You can use the rotor or a large socket as a tool to press the shutter down.
5. If riveted pickup cup could not be removed in step 1, skip to step 6. Mount the optical trigger and bracket as shown in Figure 9. If clearance is limited, install shutter and optical trigger assembly at the same time. Either side of the mounting arm can face upwards to create the proper alignment with the shutter. Attach mounting arm to mounting foot with supplied 6-32 x 3/16" screw as shown in Figures 8 and 9. To allow adjustment, do not tighten the screw completely. Skip to step 7.
6. If riveted pickup cup could not be removed in step 1, install optical trigger and mounting arm directly to a threaded hole in the cup as shown in Figure 13. Do not use mounting foot. Use an original screw and the spacer provided in the parts bag. To allow adjustment, do not tighten screw completely. In case of limited clearance, install the shutter and optical trigger assembly at the same time.

Figure 13. Hitachi Distributor



7. Pass optical trigger cable through exit hole used for the OE pickup. If possible, use the original rubber grommet to seal the cable exit hole.
8. Adjust the optical trigger height so that the shutter rim is approximately in the middle of the trigger opening as shown in Figure 4. Check for clearance around all parts. Verify that the shutter is level and does not rub or touch. If required, readjust it. Reinstall rotor.
9. If distributor was removed, reinstall it. Align rotor tip with mark on engine. Then rotate distributor to align mark on distributor with rotor tip.
10. Proceed with ignition module installation on page 10.

NIPPONDENSO DISTRIBUTOR

1. Remove pickup coil assembly (snap off dust cover if used), and pickup coil lead wires. Keep pickup coil screws for later use. Remove reluctor by prying up using two screwdrivers as shown in Figure 11.
2. Select a vacant screw hole on the carrier plate away from obstructions. Install the mounting foot using one of the original pickup coil screws. Refer to Figures 8 and 9 for orientation. To allow adjustment, do not tighten screw completely.

3. Attach mounting arm to optical trigger with supplied 4-40 x 3/16" screw as shown in Figure 8. To allow vertical adjustment of optical trigger, do not tighten screw completely.
4. Select the best fitting shutter with the same number of slots as cylinders for your application. Slide shutter onto the distributor shaft until firmly seated and level. Make sure that the flat inside the shutter lines up with the distributor shaft. You can use the rotor or a large socket as a tool to press the shutter down.
5. Mount the optical trigger and bracket as shown in Figure 9. If clearance is limited, install shutter and optical trigger assembly at the same time. Either side of the mounting arm can face upwards to create the proper alignment with the shutter. Attach mounting arm to mounting foot with supplied 6-32 x 3/16" screw as shown in Figures 8 and 9. To allow adjustment, do not tighten the screw completely. Pass optical trigger cable through exit hole used for the OE pickup. If possible, use the original rubber grommet to seal the cable exit hole.
6. Adjust the optical trigger height so that the shutter rim is approximately in the middle of the trigger opening as shown in Figure 4. Check for clearance around all parts. Verify that the shutter is level and does not rub or touch. If required, readjust it. Reinstall rotor.
7. If distributor was removed, reinstall it. Align rotor tip with mark on engine. Then rotate distributor to align mark on distributor with rotor tip.

8. Proceed with ignition module installation on page 10.

LUCAS OPUS DISTRIBUTOR

12 Cylinder Jaguar with fuel injection. Refer to the notes on page 8 before proceeding with optical trigger installation.

1. Refer to Figure 14. Remove snap ring, washer, and O ring used to retain reluctor. Remove reluctor by pulling straight up. Remove the Lucas pickup. Save the screws. Cut all wires off inside distributor. Cut the grommet (location may vary) to create an opening where the optical trigger cable can exit the distributor.
2. **Lucas 8 cylinder only.** Cut off resistor mounted between two posts so that it will not interfere with shutter installation in step 5.

Figure 14. Typical Lucas Distributor Assembly

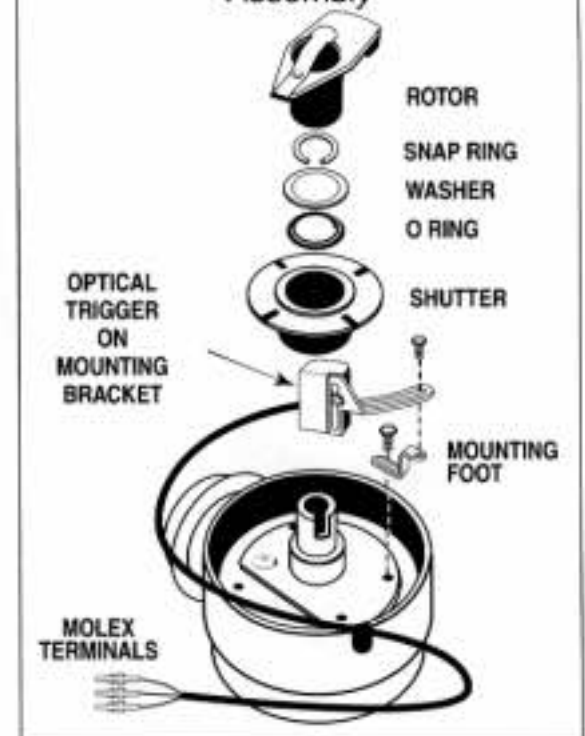

3. **Lucas distributors with combination amplifier and vacuum advance unit only.** Remove the combo amp/vac unit (held by two screws on back of distributor and one screw underneath combo unit) to gain access to wires and grommet. Cut off all wires going to combo unit. Reassemble unit after completing optical trigger installation and make sure vacuum advance arm is engaged into pin on advance plate.
4. **Lucas V12 with external amplifier.** Disassemble top and bottom halves of distributor. Remove bushing from top shaft to allow shutter installation. Refer to Figure 15 for optical trigger mounting position.
5. Select the best fitting shutter with the same number of slots as cylinders for your application. You can use the rotor or a large socket as a tool to press the shutter down. Align the large locating tab on bottom of the shutter with the large slot at the bottom of the distributor shaft. Refer to Figure 14. Reinstall O ring, washer, and snap ring to retain shutter. Some distributors use a bushing between the distributor shaft and the reluctor. Discard this part.
6. Select the best fitting mounting bracket assembly for your distributor. 4 and 6 cylinder: use one piece bracket for Lucas pickup held down by two screws. 8 cylinder: use one piece bracket. 12 cylinder: use adjustable two piece bracket assembly with mounting arm and mounting foot as shown in Figure 8.
7. Attach optical trigger to mounting arm or mounting bracket as applicable for your distributor. Use the supplied 4-40 x 3/16" screw as shown in Figure 8. If applicable, attach the mounting arm to the mounting foot with the supplied 6-32 x 3/16" screw. To allow adjustment, do not

- tighten the screws completely.
8. Pass optical trigger cable out through rubber grommet (that was cut to create an opening in step 1). Install the optical trigger and mounting bracket assembly using original screw as shown in Figures 14 or 15. If using adjustable bracket, do not tighten screw completely. In case of limited clearance, install shutter and trigger assembly at the same time.
9. Adjust the optical trigger height so that the shutter rim is approximately in the middle of the trigger opening as shown in Figure 4. Check for clearance around all parts. Verify that the shutter is level and does not rub or touch. If required, readjust it. Reinstall rotor
10. Reassemble distributor if applicable. If distributor was removed, reinstall it. Align rotor tip with mark on engine. Then rotate distributor to align mark on distributor with rotor tip.
10. **Lucas 8 cylinder only.** Verify that leading edge of shutter window is over optical trigger as shown in Figure 25. If not, go back to step 6 and use the adjustable two piece bracket assembly to mount the optical trigger.
11. Proceed with ignition module installation on page 10.

NOTES FOR JAGUAR 12 CYL WITH FUEL INJECTION

Figure 15. Lucas V12 Distributor

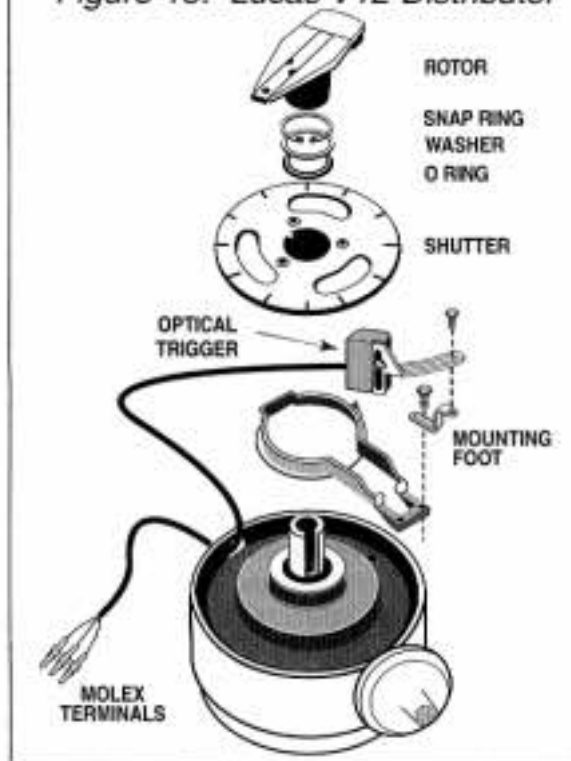

When an XR700 system is installed in V12 Jaguars with electronic fuel injection, the Lucas fuel injection trigger unit must be retained. Otherwise, the fuel injection will not function. Follow the optical trigger installation instructions above, except:

Figure 16. Lucas V12 Distributor with Fuel Injection Trigger Unit

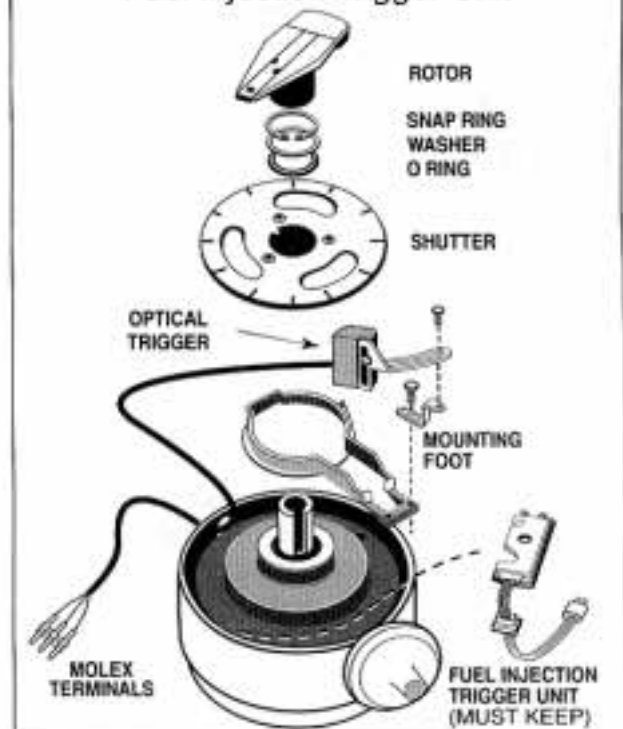

1. Refer to Figure 16. Remove the Lucas timing rotor and ignition pickup. Install the optical trigger and shutter wheel as explained above. Use the best fitting single piece bracket to mount the optical trigger.
2. The fuel injection trigger unit (held down by four screws) must be retained. Note that this trigger unit requires a special Lucas rotor that has a magnet at the rear. The magnet triggers the fuel injection trigger unit.

MALLORY YL DUAL POINT DISTRIBUTOR

1. Remove wire from dual breaker points to coil. Do not damage rubber grommet through which wire exits distributor.
2. Loosen the two screws holding the Mallory points plate and remove the plate (with attached dual points and condenser) by pulling it up. Install the new plate supplied with the optical trigger installation kit. Refer to

3. Select the best fitting shutter with the same number of slots as cylinders for your application. Install shutter on distributor shaft cam. Make sure that the flat springs inside the shutter line up with the cam flats. Use a socket to press the shutter down into position. To prevent breaking the shutter, do not press on the slotted rim.
4. Attach the optical trigger to the mounting bracket with the supplied 4-40 x 3/16" screw as shown in Figure 17. Do not over tighten this screw.
5. Adjust the optical trigger height so that the shutter rim is approximately in the middle of the trigger opening as shown in Figure 4. Check for clearance around all parts. Verify that the shutter is level and does not rub or touch. If required, readjust it. Reinstall rotor.

6. Pass optical trigger cable through exit hole used for the points wire. Attach cable to breaker plate with a nylon tie wrap. If possible, use the original rubber grommet to seal the cable exit hole. Otherwise, use silicone sealer to seal the hole.
7. Proceed with ignition module installation on page 10.

MALLORY UNILITE DISTRIBUTOR

1. Remove the Unilite module from the distributor. Clean the grease from the mounting plate.
2. Refer to Figure 18. Attach the optical trigger to the mounting bracket with the supplied 4-40 x 3/16" screw. The mounting bracket attaches to the original distributor plate and the optical trigger will face up to match the Mallory Unilite combination rotor/shutter. Use a cable tie to attach the optical trigger cable to the small strain relief tab on the mounting bracket.

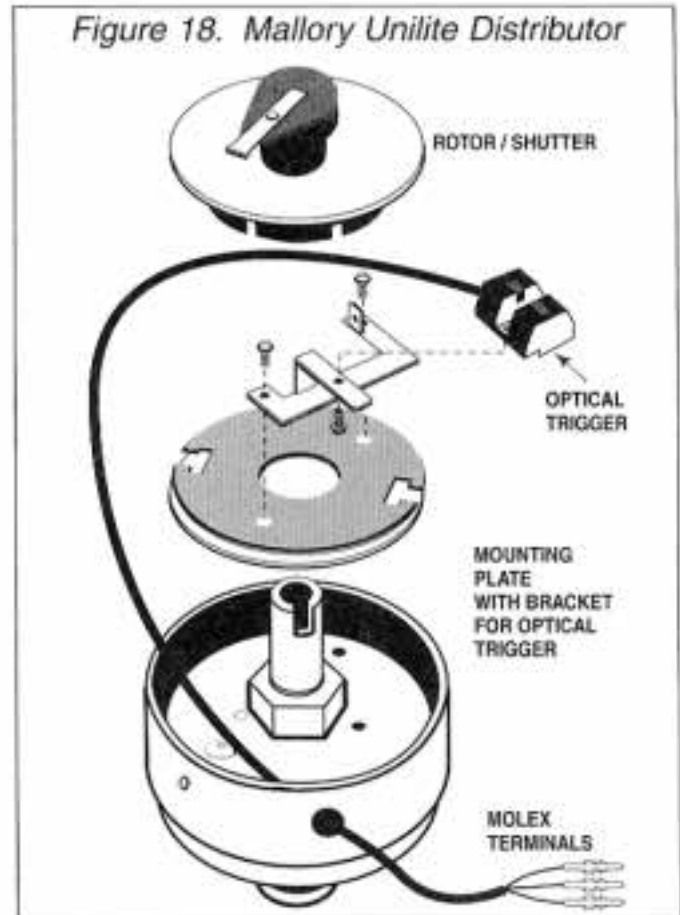
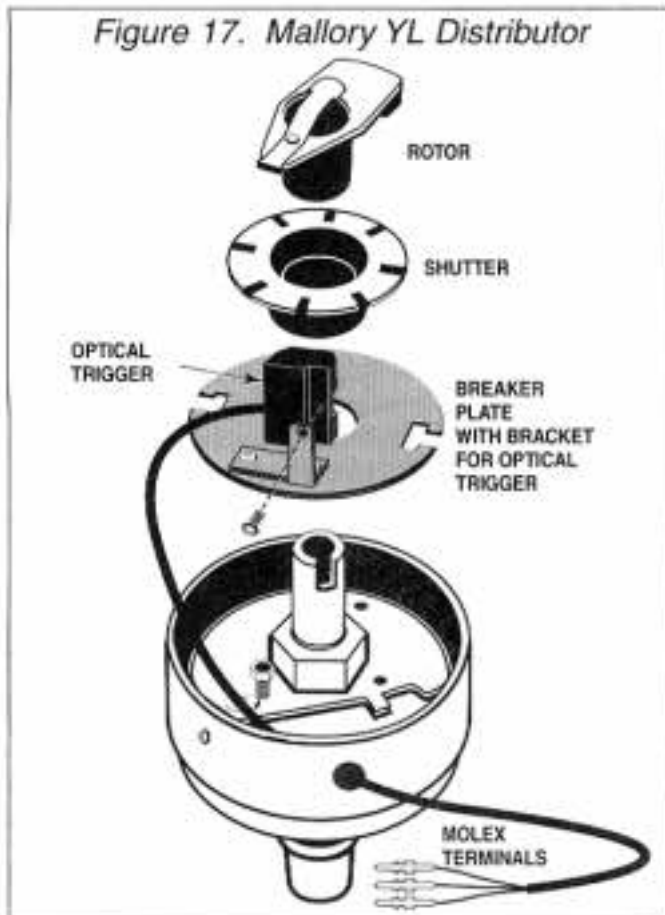

3. Install the optical trigger and bracket assembly on the distributor plate in the same position where the Unilite module was mounted. Use the screws that held the Unilite module.
4. Pass optical trigger cable through exit hole used for the Unilite wires. Leave enough slack to allow movement of vacuum advance mechanism (if equipped). If possible, use the original rubber grommet to seal the cable exit hole. Otherwise, use silicone sealer to seal the hole.
5. Reinstall the Mallory Unilite combination rotor/shutter. Check for clearance between shutter and optical trigger.
6. Proceed with ignition module installation.

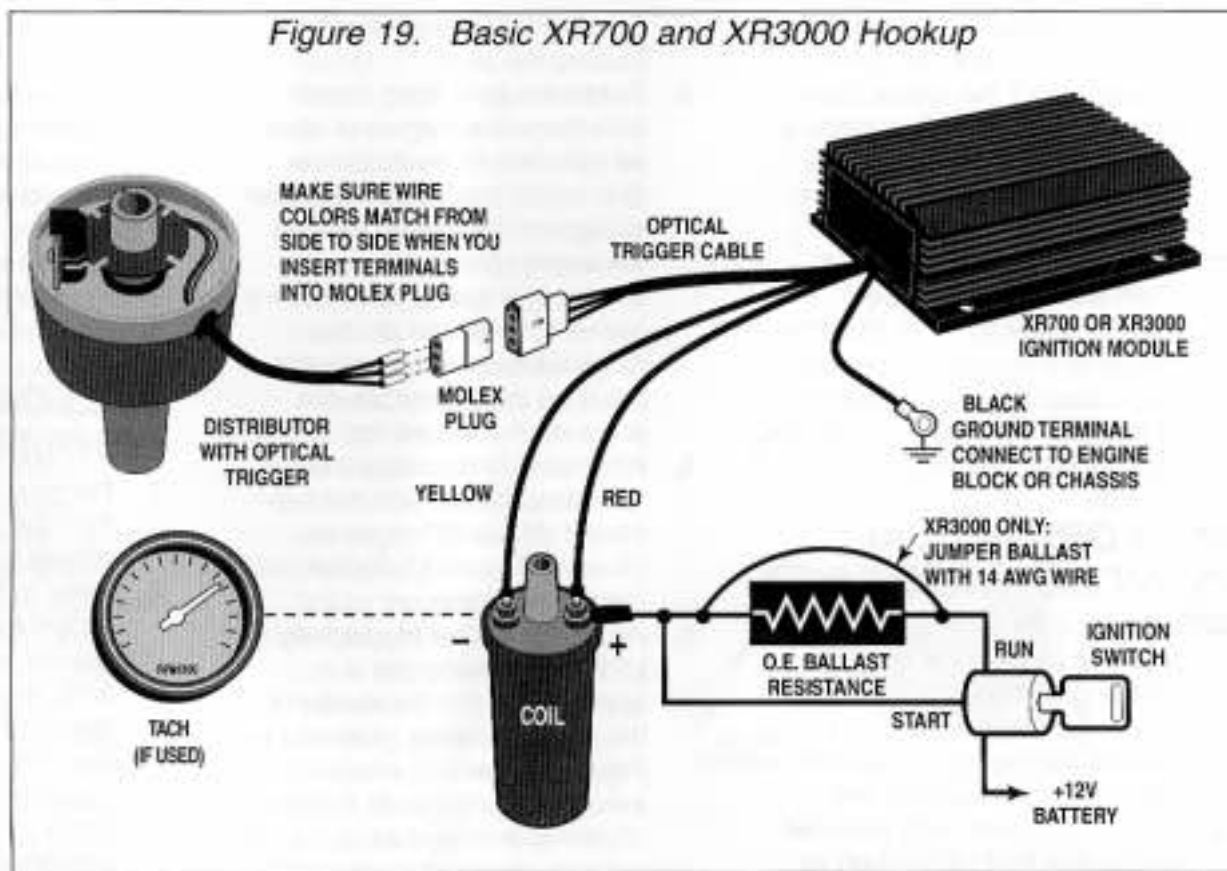

IGNITION MODULE INSTALLATION

This section covers 12 volt negative ground installations only. Refer to Appendix for 6 volt and positive ground vehicles and applications where the XR700 is used to trigger a CD ignition. Note that XR3000 can only be used in 12 volt negative ground applications.

1. Mount the XR700 or XR3000 ignition module in any convenient location on the firewall or a fender well. Avoid locations directly exposed to engine or exhaust header heat or where water can splash. Do not mount it on the engine. Use the two sheet metal screws provided to mount the ignition module. Make sure that the wires will reach to the coil and distributor with some slack for engine movement.
2. **Basic wiring hookup is shown in Figure 19. Use this figure for all applications except certain Lucas Opus applications described below. Before you connect the wires, check to see if sections 3 to 8 apply to your application.**
3. **Bosch systems.** Disconnect and remove the OE Bosch module. Use electrical tape to tape off both the module plug and plug at distributor on OE harness. To avoid disconnecting accessories (such as tach), do not cut plugs off or remove any

wires at coil. XR700 or XR3000 module connections will be made at the Bosch coil. Proceed to step 9.

4. **Hitachi systems.** Disconnect and remove OE module. Some Hitachi modules are located in the passenger compartment. Use electrical tape to tape off all wires that ran to the Hitachi ignition module. To avoid disconnecting accessories (such as tach), do not remove any wires at coil or ballast resistor. XR700 or XR3000 module connections will be made at the coil terminals. Proceed to step 9.
5. **Nippondenso systems.** The OE Nippondenso module (ignitor) is mounted on the coil. Disconnect and remove the ignitor. Use electrical tape to tape off all wires that ran to ignitor. To avoid disconnecting accessories (such as tach), do not remove any other wires to coil or ballast resistor. XR700 or XR3000 module connections will be made at the coil terminals. Proceed to step 9.

6. **Triumph and MG with Lucas Opus combination amplifier and vacuum advance unit mounted on distributor.** Refer to Figure 20. Use electrical tape to tape off the plug on the vehicle wire harness that went to the Lucas amplifier. XR700 module connections will be made to the coil terminals. Other Lucas connections are shown for reference only. No wiring changes are required. You can skip the following section about ballast resistance. Proceed to step 9.

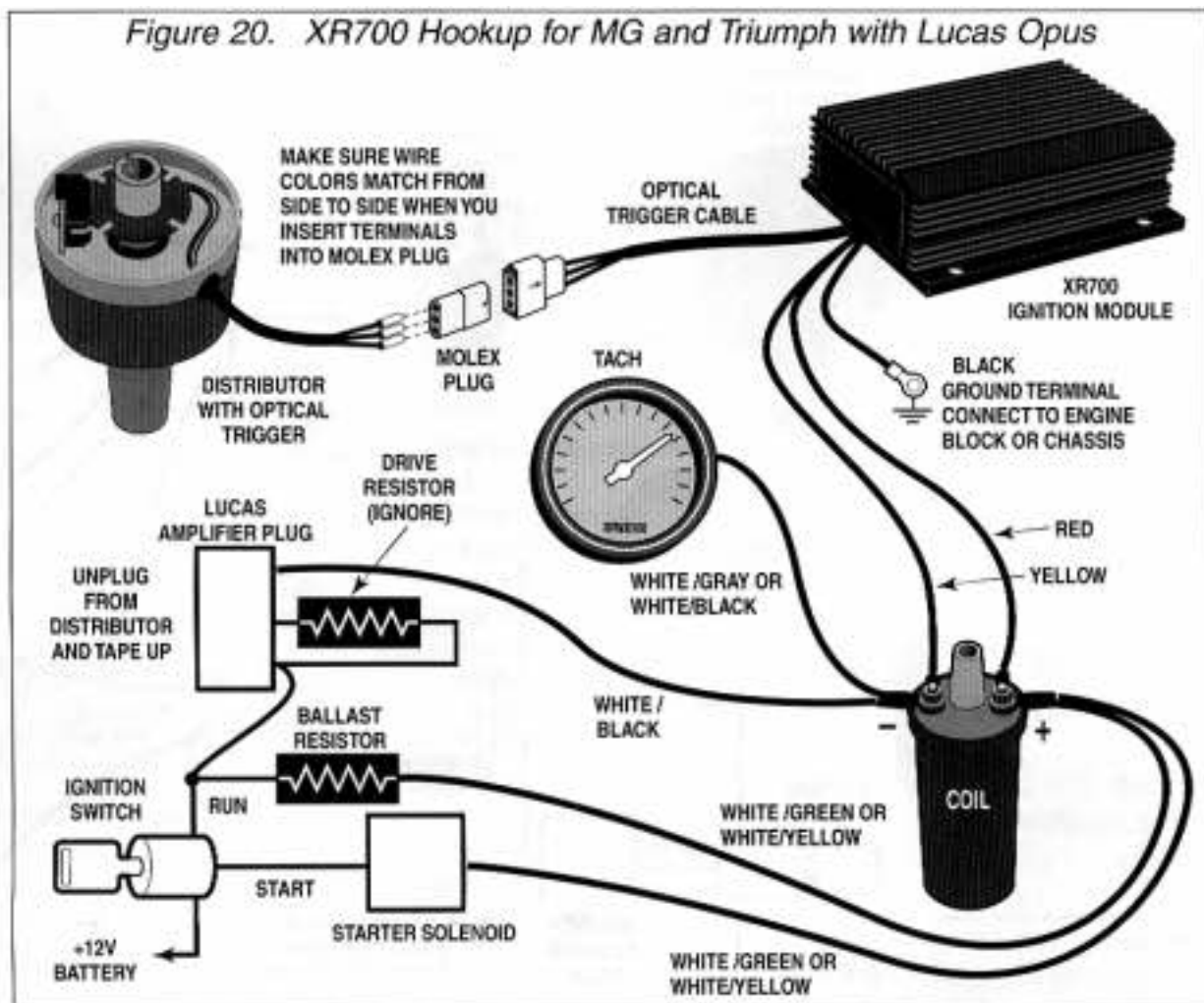

7. **All Jaguar.** Refer to Figure 21. Disconnect the Lucas amplifier. Removal of external amplifier is optional. Use electrical tape to tape off the plugs on the vehicle wire harness that went to the Lucas amplifier and/or distributor. XR700 module connections will be made to the coil terminals. Add the diode wire as shown. The black end of the diode wire (with attached ring terminal) is connected to COIL-, the other end goes to the Lucas ballast resistor as shown. Other Lucas connections are shown for reference only. No wiring changes are required. However, make sure you do not break the connection from COIL- to the ECU on fuel injected vehicles. You can skip the following section about ballast resistance. Proceed to step 9.

8. **Lucas Opus distributor in vehicles with modified wire harness.** Use the basic hookup shown in Figure 19. Rewire the vehicle as required.
9. Connect the XR700 or XR3000 black wire to ground on the chassis or engine block. An existing bolt or screw can be used, but scrape away paint and corrosion to insure a good ground.
10. Check and double check the identification of COIL+ and COIL- terminals. **Improper coil connection may damage ignition module.** Bosch coils are labeled as follows: terminal 1 is COIL- and terminal 15 is COIL+. Some English coils use SW for COIL+ and CB for COIL-. If you are not sure which terminals are COIL+ and COIL-, use the following procedure. Label and then disconnect OE

wires from coil. Reconnect battery and turn ignition key on. Use a 12V test light or voltmeter. The wire from the ignition switch to COIL+ will be hot.

11. Tach connection (skip if not equipped). Except for Smiths current sensing tachometers found on older English vehicles, the tach wire typically goes to COIL-. Vehicles with Smiths tach, refer to Smiths Tach Tech Note in Appendix.
12. **Jaguar only.** Some tachs may not work with the diode wire hookup shown in Figure 21. If your tach doesn't work, try a direct connection between the ballast resistor and COIL- in place of the diode wire.
13. Insert the three terminals on the end of the cable from the optical trigger assembly into the Molex plug supplied with the installation kit. Make sure that

the individual wire colors match from side to side. Use a small screwdriver to push the terminals all the way into the Molex plug. Then connect it to the mating Molex plug on the cable from the module. If you must remove a terminal, see Figure 22 and use the provided extraction tool.

BALLAST RESISTANCE

Study the ballast resistance sections carefully. Most installation problems result from improper ballast resistance.

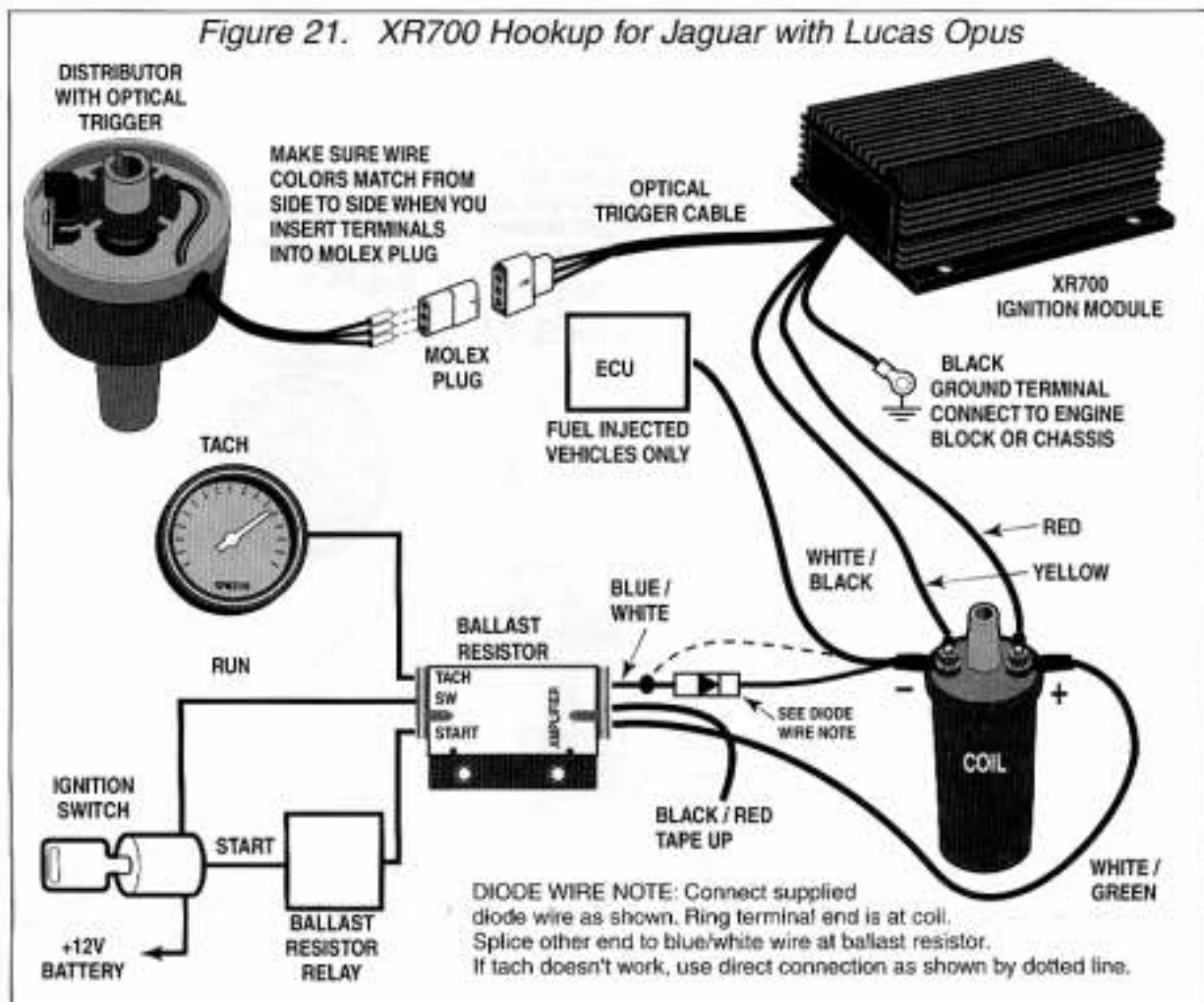

1975 and later VW vehicles have a resistance wire. Most Chrysler models use a ceramic resistor. Ballast resistance can also be in the form of internal resistance within the coil. Bosch

blue coils (used with many pre-1975 VW models) and some Lucas coils have internal resistance. Coils with internal resistance will measure 3 to 4 ohms from COIL- to COIL+ terminals.

1. All vehicles with OE breaker points ignition are factory equipped with ballast resistance. This can be external resistance in the form of a ceramic ballast resistor or a resistance wire between the ignition key and COIL+ terminal. Most AMC and GM and

Figure 22. Terminal Removal

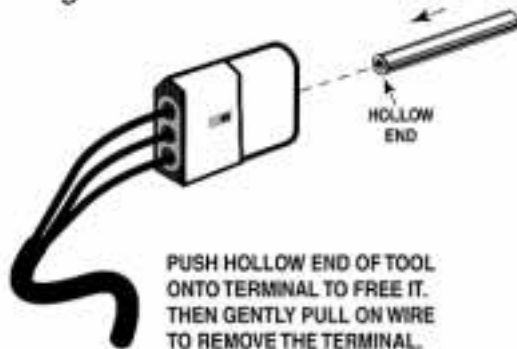

Quick Test for Ballast Resistance

You can determine if your vehicle has external ballast resistance with this simple test. Disconnect any wires going to COIL-. Reconnect battery. Turn the ignition key on but do not start the engine. Use a volt meter as shown in Figure 23 and read voltage between COIL+ terminal and ground. It should be about 12 volts. Then momentarily jumper the COIL- terminal to ground. If voltage at COIL+ terminal drops below 8 volts, there is ballast resistance between the ignition key and COIL+ terminal. To determine if your coil has internal ballast resistance, use an ohm meter as shown in Figure 24. Coils with internal resistance will read 3 to 4 ohms from COIL- to COIL+ terminals.

2. Bosch, Hitachi, and Nippondenso OE electronic ignition replacement only. Most vehicles are factory equipped with an external ballast resistor between the ignition key and COIL+ terminal. Refer to vehicle service manual. Bosch Hall Effect systems do not have any ballast resistor.

XR700 BALLAST RESISTANCE NOTES

If the XR700 runs very hot to the touch after 15 minutes of operation, you must add a ballast resistor.

1. If you have a Bosch Hall Effect system or other system without ballast resistance, you will need to add a 1.2 to 1.9 ohm ballast resistor. Use a Chrysler style two terminal ballast resistor such as Echlin ICR23 or Wells CR107. Connect the ballast resistor between the COIL+ terminal and ignition switch as shown in Figure 19.
2. **1979-80 Honda (excluding Civic and California automatic transmission Accord/Prelude) only.** These models use a Hitachi ignition and coil with internal ballast resistance. If you change to an aftermarket coil, you must add a ballast resistor.
3. **Nippondenso system with three terminal ceramic ballast resistor only.** If the engine will not start or the starter runs on, request the Nippondenso Tech Note. The system will require addition of a diode.
4. If you are changing coils and your vehicle has a ceramic ballast resistor or resistance wire, do not use any additional bal-

Figure 23. External Ballast Resistance Test

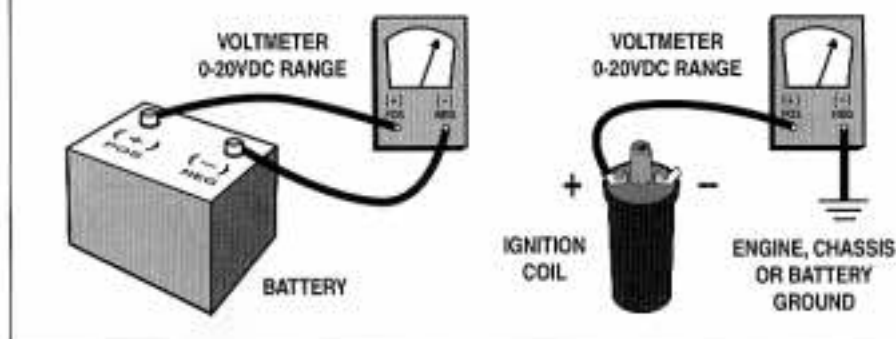

last resistor that may be provided with the coil.

5. If your OE coil had internal resistance and you are changing to a new coil with lower resistance (such as an after-market performance coil), you must add a 1.2 to 1.9 ohm ballast resistor. If a resistor is not supplied with the new coil, use a Chrysler style two terminal ballast resistor such as Echlin ICR23 or Wells CR107. Connect the ballast resistor between the COIL+ terminal and ignition switch.

XR3000 BALLAST RESISTANCE NOTES

For maximum performance, any external ballast resistance must be bypassed. Refer to Figure 19. Locate external ceramic ballast resistor or resistance wire. Bypass it with heavy 14 AWG stranded wire. If this is not practical, refer to the Ignition Power Relay Tech Note in the Appendix on page 17.

1. **1979-80 Honda (excluding Civic and California automatic transmission Accord/Prelude) only.** These models use a Hitachi ignition and coil with internal ballast

Figure 24. Coil Resistance Test

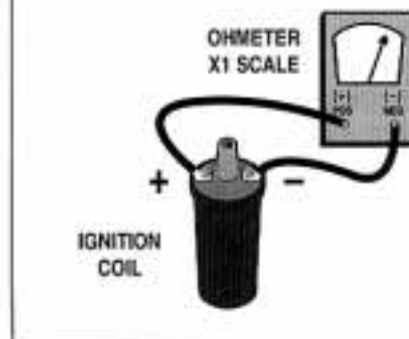

resistance. If the coil resistance measures more than 1.5 ohms from COIL- to COIL+ terminals, you must replace the coil. We suggest using a Crane PS60, LX91, or PS91 coil.

2. All Bosch blue coils, Lucas coils, and other OE coils with internal ballast resistance must be replaced. Use a Crane PS60, LX91, or PS91 coil.

OPTICAL TRIGGER ADJUSTMENT PROCEDURE

If you have a 700-0226, 3000-0226, or 700-0309 kit that uses a non-adjustable one piece bracket for the optical trigger, you can skip this section.

1. Remove high voltage coil wire from distributor cap and place tip of wire approximately 3/8" from metal chassis or engine

block for spark testing. Tape it down. Do not hold it with your hand.

2. Reconnect the battery. Turn ignition key on, but do not crank engine. **Timing marks must remain aligned.**
3. Refer to Figure 25. Select the appropriate orientation depending on direction of rotation previously noted. Slide trigger assembly around the edge of shutter in direction opposite to distributor shaft rotation. When the light beam from the optical trigger reaches leading edge of a window in the shutter, a spark will be fired from coil wire. When the spark fires, stop sliding the optical trigger. Tighten all screws to maintain this position. If necessary, repeat sliding procedure until you are sure optical trigger is aligned properly. You can position the mounting arm either to the left or to the right of the mounting foot as required for proper alignment.
4. This alignment procedure assures that the rotor is pointing directly towards a spark plug terminal when the leading edge of a shutter window reaches the optical trigger. Correct alignment assures maximum spark energy by reducing the gap between the rotor tip and cap terminal.
5. Attach optical trigger cable to breaker plate with a nylon tie wrap. Leave enough slack to allow movement of vacuum advance mechanism. If possible, use the original rubber grommet to seal the cable exit hole. Otherwise, use silicone sealer to seal wire exit hole.

COMPLETING THE INSTALLATION

1. Double check all connections. Reconnect the battery if you have not already done so. Unplug optical trigger Molex plugs to keep ignition from

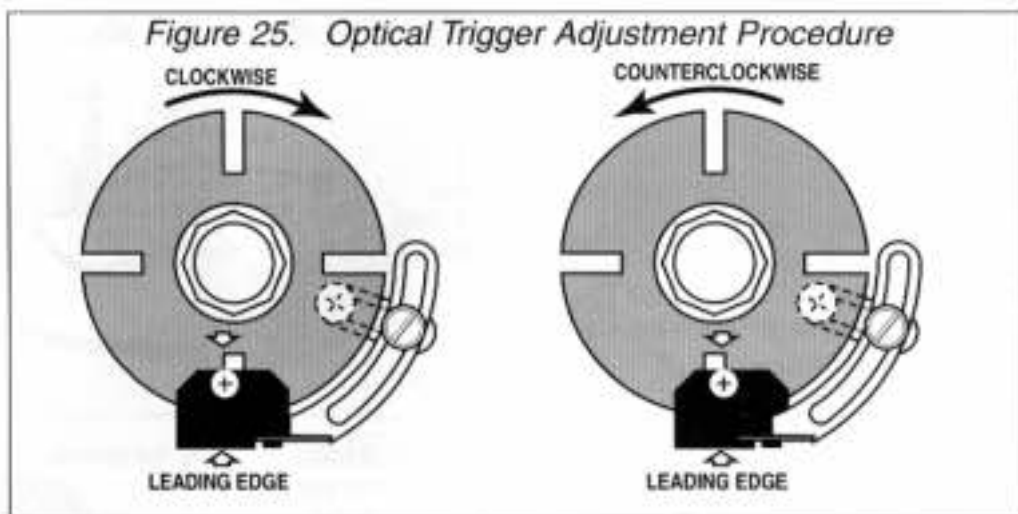

sparkling while distributor cap is off. Momentarily crank engine and visually check for clearance around all parts. Make sure that the shutter is level and does not wobble as it turns. If the shutter rubs the optical trigger, readjust it. Reinstall distributor cap and reconnect Molex plugs.

2. Start your engine and set ignition timing according to manufacturer's specifications. Note: Dwell meter readings are meaningless with electronic ignition and should be ignored.
3. A final check of distributor phasing is highly recommended, especially for installations that use an adjustable bracket for the optical trigger. Many problems with rough running or misfiring are related to improper phasing. To check the phasing, cut or drill a large hole in the distributor cap near a terminal

as shown in Figure 26. Use a timing light connected to that terminal and observe rotor alignment when the engine is running. The rotor tip should be aligned with the terminal as shown in the figure. If not, you must adjust the optical trigger position. Install a new distributor cap when you are done.

TROUBLESHOOTING

TACH INOPERATIVE

1. With the exception of Smiths current sensing tachs (refer to page 16), most tachs are connected to the COIL- terminal. If the tach is inoperative, trace out the wire. Refer to the vehicle service manual for further information.

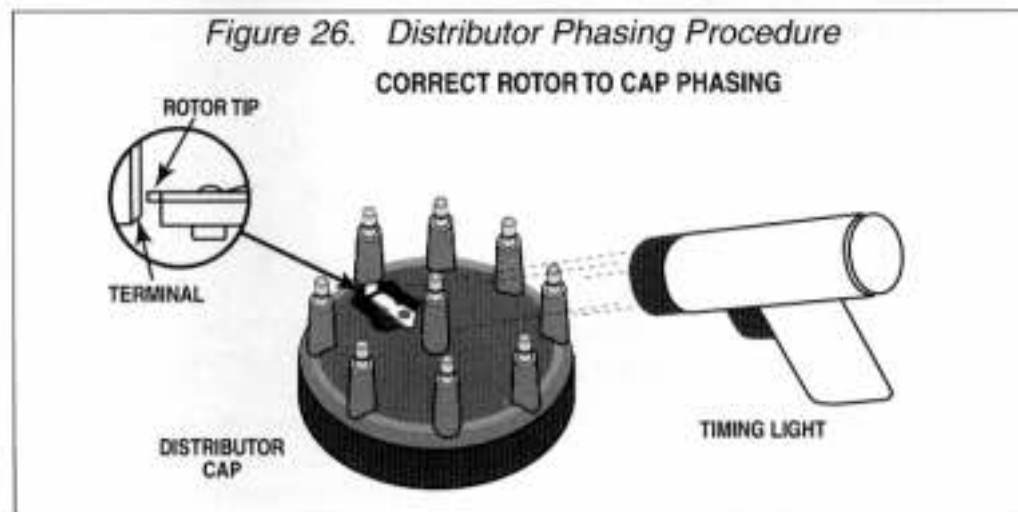

2. Some Jaguar applications applications require a diode wire. Refer to Figure 21 on page 12.
3. If the tach is erratic or reads high, you can put a resistor in the tach wire to reduce the signal level. Start with a 10K ohm 1/2 watt. You can go as low as 1K ohm 1/2 watt. You can buy the resistors from Radio Shack or other electronic suppliers. Solder into tach wire and wrap with electrical tape for protection. If the resistor fix does not help, you may require a tach adapter. Refer to page 20.
4. Some Mercedes and Porsche applications that were originally equipped with factory capacitive discharge (CD) ignitions have tachs that are not compatible with XR700 or XR3000 systems. You must install an after-market tach or later model OE tach.

ENGINE WILL NOT START

1. Pull the high voltage coil wire out of the distributor and place it 3/8" away from ground. Crank the engine. If sparks fire, the problem is in the secondary system. Possible causes: rotor left out, rotor, cap, or spark plug wires defective, or timing or phasing is off (optical trigger not properly aligned, distributor was moved, or plug wire firing order was changed).
2. If there are no sparks, connect a test light between COIL- (negative) terminal and ground. Crank the engine. If the light flashes on and off, the trigger and module are okay, but the coil may have failed. Try another coil.
3. If the light does not flash, repeat test in step 2 with a known good coil. Try disconnecting any wires to COIL- than the yellow wire from the Crane module. The only extra wire nor-

mally connected to COIL- is the tach wire (or Lucas diode wire). If the light still does not flash, check electrical connections and optical trigger as explained in the following sections.

4. Fuel injected vehicles only. The fuel injection system typically requires a trigger signal from the COIL- terminal. Refer to vehicle service manual for details.

CHECK ELECTRICAL CONNECTIONS

1. Check ground connection. Try a different ground connection point on the engine block or metal chassis. Make sure the ground point is free of paint and corrosion.
2. Check voltage at COIL+ (positive) terminal while cranking engine. Reading should be at least 9 volts. If less than 9 volts, check battery and starter system. If the reading is close to zero, check wiring back to ignition switch and battery. Some applications use a starter bypass to bypass the ballast resistor while cranking. This wire comes from the starter solenoid, relay, or ignition switch. Check your wiring diagram.
3. **XR3000 only.** You must bypass any ballast resistance or install the power relay as explained on page 17. Run the test for ballast resistance on page 13.

CHECK OPTICAL TRIGGER

1. Verify that wire colors match from side to side on Molex plugs, i.e. white to white, black to black, and gray to gray.
2. Pull high voltage coil wire out of distributor and place 3/8" from ground. Disconnect Molex plugs. Turn ignition key on. Rapidly tap a screwdriver blade between the white and gray wires on Molex plug on cable

from module. XR3000 will automatically shut coil current off unless it receives at least two trigger pulses per second. Tapping screwdriver should cause coil to fire. If sparks fire, the module is okay, but optical trigger may be misaligned or may have failed. If coil doesn't fire, the module may have failed.

ROUGH OR INTERMITTENT OPERATION

1. Improper phasing is the most likely cause of rough running on new installations. Check phasing according to instructions in the section on Completing the Installation.
2. Check for disconnected or cracked vacuum hoses, stuck PCV valve, or clogged fuel filter. These problems may cause symptoms similar to ignition trouble.
3. Check electrical connections and optical trigger as explained in the above sections. Check for loose or corroded connections and broken wires. Try a different ground connection point on the engine block or chassis. Check distributor for loose or misaligned parts in optical trigger assembly or advance mechanism.
4. **XR3000 only.** If a miss occurs at high RPM, make sure any ballast resistance has been bypassed.
5. Replace spark plugs. Check for proper heat range and gap size. Replace rotor, cap, spark plug wires, and coil.

APPENDIX

SMITHS TACH TECH NOTE

There are three types of Smiths tach: external current loop, internal current loop, and electronic pulse sensing (late models). Current sensing tachs have a wire loop with two turns that passes the coil current through a pickup at the tach. This loop can be external or internal. Electronic tachs have a trigger wire that connects to the COIL- terminal.

MODIFICATION OF SMITHS CURRENT SENSING TACHS

Some older British vehicles use Smiths current sensing tachs. The wire from the coil positive terminal to the ignition switch passes through a current pickup at the tach. Installation of a Crane electronic ignition may cause erratic operation of a current sensing tach, due to the higher coil current. Modification of the current pickup to reduce the signal level will usually eliminate the problem.

1. Remove the Smiths tach from the instrument panel. The tach has two threaded studs that are retained from the rear of the panel. Label all wires to avoid errors upon reinstallation.
WARNING: Improper connection may damage the tach.
2. Locate the external current pickup on the rear of the tach. Refer to Figure 27. If your tach does not resemble this figure but has coil and ignition key wires going to a plug, it may have an internal current pickup. In this case, it will be necessary to disassemble the tach. Once the tach is disassembled, you can use the same general procedure as explained in step 3.

3. Modify the current pickup by removing one loop of wire as shown in Figure 28. Note the direction that the wire passes through the pickup. If this direction is reversed, the tach will not function.
4. Recalibrate the tach for best accuracy. Connect a test tach and have a helper rev the engine. Hold the tach in the same position it is mounted (orientation may affect calibration). Adjust the calibration screw on the back of Smiths tach until the reading matches the test tach. 4,000 RPM is a reasonable engine RPM to use for calibration. Please note that older Smiths tachs may vary as much as 500 RPM throughout the RPM range. This variation is not the fault of the ignition system.
5. Reinstall tach in instrument panel. Check all wire connections.

TROUBLESHOOTING SMITHS ELECTRONIC TACHS

In some cases the tach will not read the correct RPM after installation of a Crane electronic ignition. A calibration screw on the back of the tach can usually be adjusted to give correct readings. If the tach still reads high, put a resistor in the tach wire to reduce the signal level. Start with a 10K ohm 1/2 watt. You can go as low as 1K ohm 1/2 watt. You can buy the resistors from Radio Shack or other electronic suppliers. Solder into tach wire and wrap with electrical tape for protection.

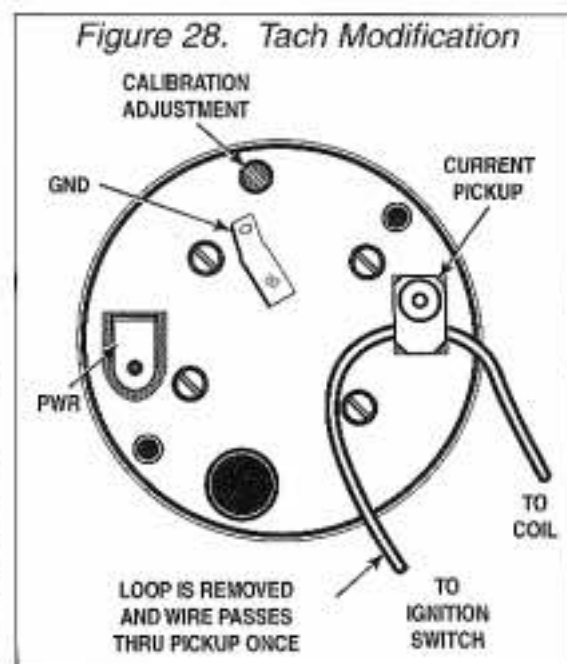
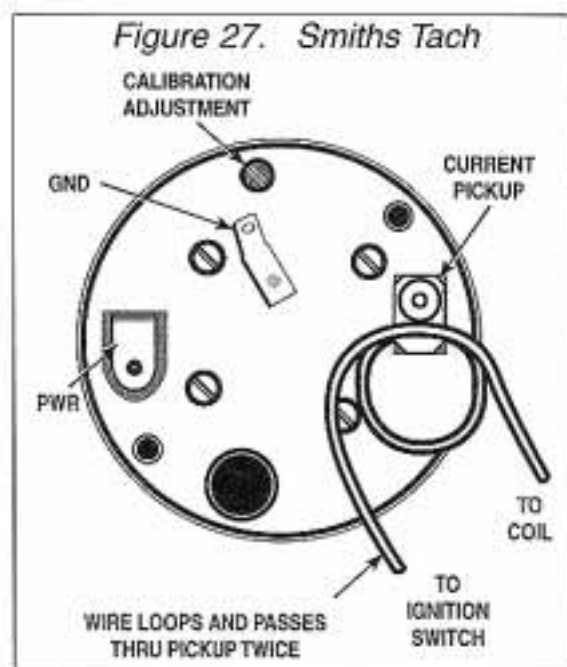

POWER RELAY TECH NOTE

XR3000 ignition systems require a direct +12V power connection between the ignition switch and the positive coil terminal. Most AMC, Chrysler, and Ford vehicles are equipped with OE resistance wires or ballast resistors. All pre-1974 GM vehicles (without HEI ignition) are equipped with OE resistance wire. The ballast resistor or resistance wire must be bypassed to establish a direct +12V connection. In some cases, adding an ignition power relay circuit may be an easier alternative.

PARTS REQUIRED FOR POWER RELAY INSTALLATION

30 Amp auto relay (Radio Shack 275-226 or NAPA AR274)

3 Amp 400 volt diode (Radio Shack 276-1144) or similar part (1N4004-1N4007 or 1N5404-1N5408)

14 Gauge stranded copper wire and crimp terminals

POWER RELAY INSTALLATION

1. Refer to Figure 29. Install ignition power relay only. Do not install diode at this time. Break connection from ignition switch to ignition coil positive terminal and connect to relay terminals 86 and 30 as shown. Connect relay terminal 85 to ground. Connect relay terminal 87 direct to +12V on battery. Use 14 gauge wire. Use 1/4" female quick disconnect crimp terminals to connect to relay. Ground and +12V battery connections can be made with ring tongue crimp terminals.

2. The ignition power relay will now switch +12V power direct from the battery to the coil positive terminal when the ignition switch is turned on. Test proper operation of circuit by starting engine and then turning ignition key off. If engine continues to run, momentarily disconnect ground (terminal 85) at relay to stop engine and proceed to step 3. If engine stops running when key is turned off, diode installation is not required and installation of ignition power relay is complete.
3. Isolation diode. Most pre-1974 GM vehicles equipped with Delcotron alternators with external regulator and most Ford vehicles with Autolite/Motorcraft alternators with external regulator will require isolation diode installation. The isolation diode prevents current from the regulator flowing back to the ignition

- power relay when the key is turned off.
4. Locate terminal on voltage regulator that is connected to charge indicator light. This is terminal I on most Ford regulators and terminal 4 on most GM regulators. A top view of the regulator is shown in Figure 29 to help with terminal identification. Break the wire going to this terminal and solder the diode to the wire ends. Observe diode polarity indicated by a "band" on the diode. Wrap diode and wires with electrical tape. Make sure diode or bare wires cannot touch any metal surface.
5. Verify proper operation of charging circuit and ignition system. If charge indicator light does not light up when key is turned on before engine is started, diode was probably installed backwards.

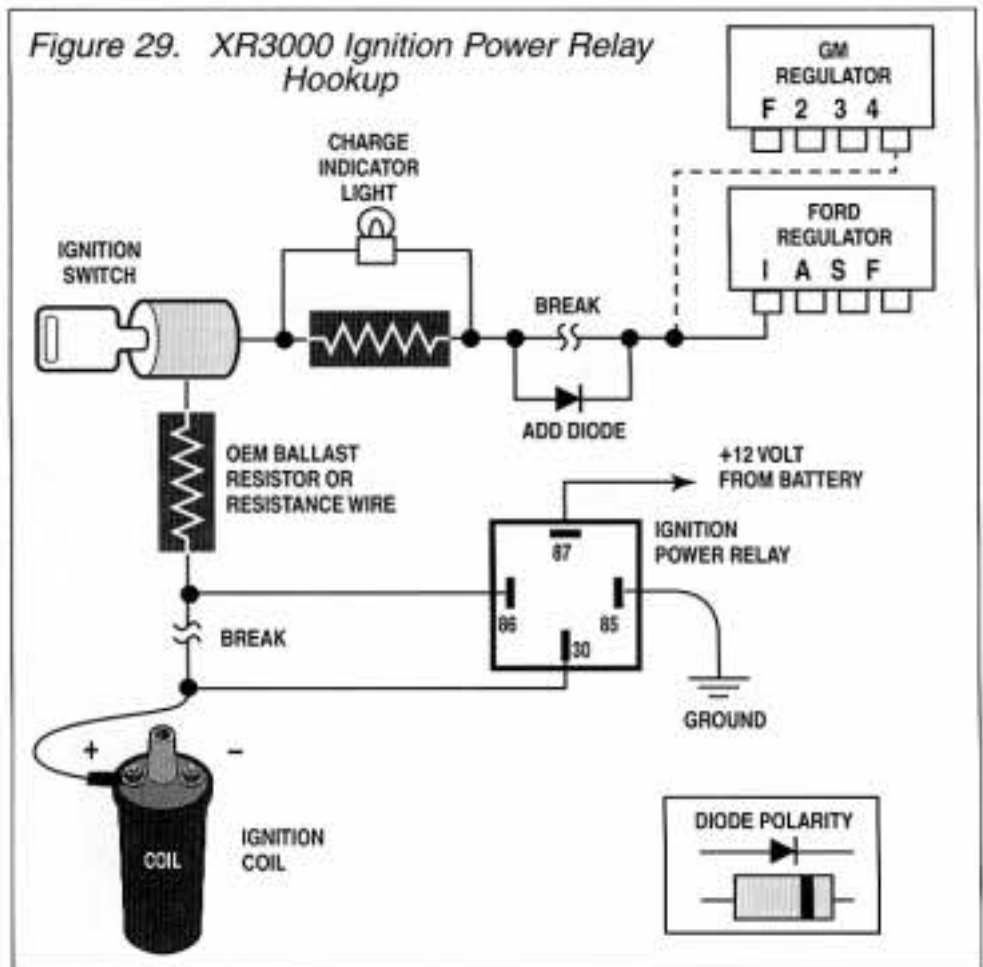

12 VOLT POSITIVE GROUND TECH NOTE

WARNING: Use this hookup only for special XR700 12 volt positive ground ignition part number 720-0231. Do not use standard XR700 12 volt units for positive ground!

Follow the standard installation instructions for the optical trigger. Then follow the steps below to install the ignition module:

1. Mount the XR700 ignition module in any convenient location on the firewall or a fender well. Avoid locations directly exposed to engine or exhaust header heat or where water can splash. Do not mount it on the engine. Use the two sheet metal screws provided to mount the XR700 module. Make sure that the wires will reach to the coil and distributor with some slack for engine movement.
2. Use the wiring diagram in Figure 30. Remove all original wires from coil. Connect original wire that went to tach or ignition switch to XR700 black wire as shown. Connect XR700 yellow and red wires to coil as shown. Connect COIL+ terminal to chassis ground as shown.

3. Insert the three terminals on the end of the cable from the optical trigger assembly into the Molex plug supplied with the installation kit. Make sure that the individual wire colors match from side to side. Use a small screwdriver to push the terminals all the way into the Molex plug. Then connect it to the mating Molex plug on the cable from the module. If you must remove a terminal, see Figure 22 and use the provided extraction tool.
4. Continue with the standard installation instructions starting at the Ballast Resistance section on page 13. If the XR700 runs very hot to the touch after 15 minutes of operation, you may have excessive coil current and you must add a ballast resistor. Use a Chrysler style two terminal ballast resistor such as Echlin ICR23 or Wells CR107.

6 VOLT TECH NOTE

WARNING: Use this hookup only for special XR700 6 volt ignition part number 700-6231. Do not use standard XR700 units for 6 volt applications!

Follow the standard installation instructions for the optical trigger. Then follow the steps below to install the ignition module:

1. Mount the XR700 ignition module in any convenient location on the firewall or a fender well. Avoid locations directly exposed to engine or exhaust header heat or where water can splash. Do not mount it on the engine. Use the two sheet metal screws provided to mount the XR700 module. Make sure that the wires will reach to the coil and

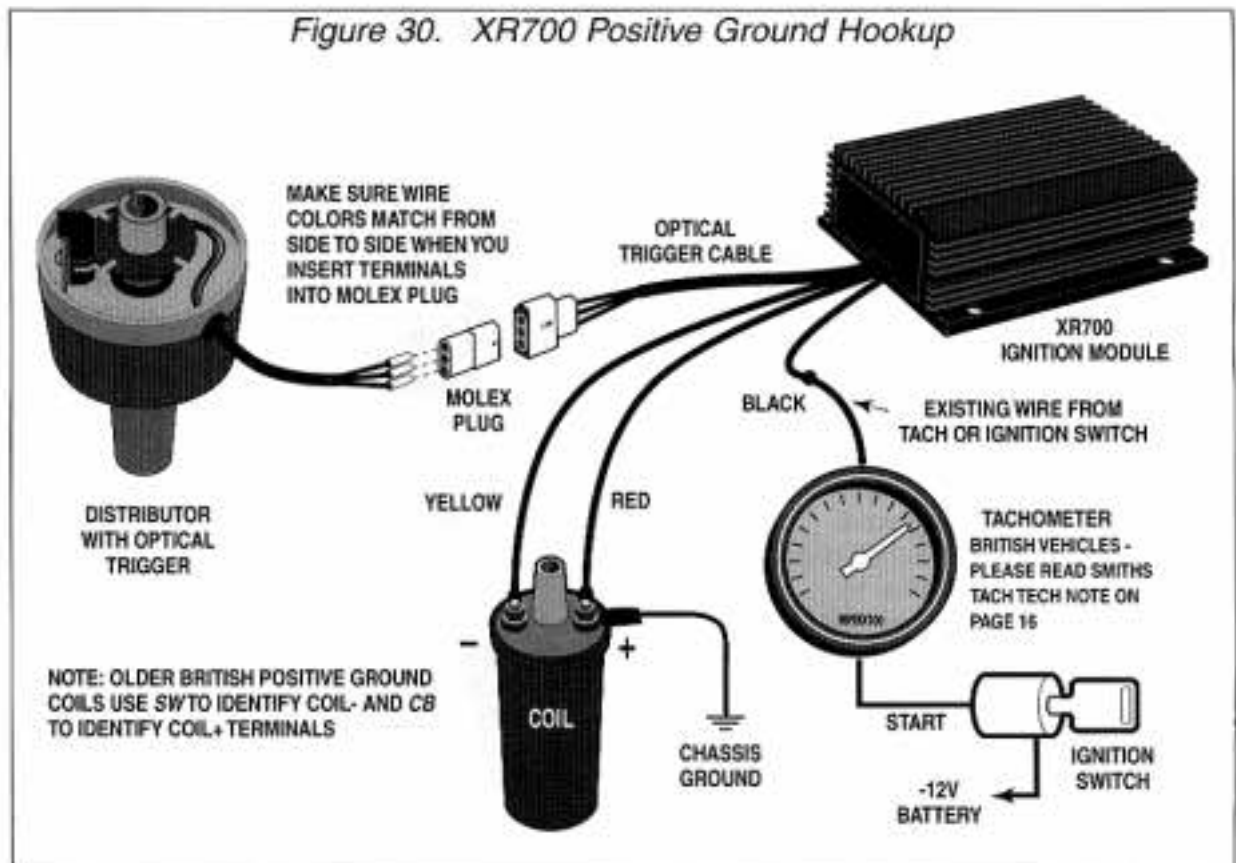

distributor with some slack for engine movement.

2. **Negative ground systems only.** Use the wiring diagram in Figure 19 and standard XR700 ignition module installation instructions on page 10. Then skip to step 4.
3. **Positive ground systems only.** Use the wiring diagram in Figure 30. Remove all original wires from coil. Connect original wire that went to tach or ignition switch to XR700 black wire as shown. Connect XR700 yellow and red wires to coil as shown. Connect COIL+ terminal to chassis ground as shown.
4. Ignition coil. Replace the original ignition coil. Use a Borg Warner E-1 type 6 volt ignition coil or equivalent. You cannot use any 12 volt ignition coil.
5. Ballast resistance. 6 volt systems use coils with internal ballast resistance. An external ballast resistor is never required.
6. Check wiring. Because of the low voltage, losses from corroded terminals or inadequate wiring are more critical in 6 volt systems. We recommend using heavy 14 or 16 gauge stranded copper wire for all connections. Replace any questionable wiring in older vehicles.
7. Insert the three terminals on the end of the cable from the optical trigger assembly into the Molex plug supplied with the installation kit. Make sure that the individual wire colors match from side to side. Use a small screwdriver

to push the terminals all the way into the Molex plug. Then connect it to the mating Molex plug on the cable from the module. If you must remove a terminal, see Figure 22 and use the provided extraction tool.

8. Continue with the standard installation instructions starting at the Optical Trigger Adjustment Procedure section on page 14.

CD TRIGGER TECH NOTE

Follow the standard installation instructions for the optical trigger. Then follow the steps below to install the ignition module:

1. Mount the XR700 ignition module in any convenient location on the firewall or a fender well. Avoid locations directly exposed to engine or exhaust header heat or where water can splash. Do not mount it on the engine. Use the two sheet metal screws provided to mount the XR700

module. Make sure that the wires will reach to the CD ignition and distributor with some slack for engine movement.

2. Wiring hookup is shown in Figure 31.
3. Connect the XR700 black wire to ground on the chassis or engine block. An existing bolt or screw can be used, but scrape away paint and corrosion to insure a good ground.
4. Connect the XR700 yellow wire to the trigger input of the CD ignition. This is typically a white wire on Crane HI-6 and MSD-6 units. Refer to the installation instructions for the CD unit. The XR700 generates a "points" type trigger signal.
5. Connect the XR700 red wire to the same source of switched +12 volt power used for the CD ignition.
6. Tach connection (skip if not equipped). **Do not connect the tach wire to Coil-.** Crane HI-6: connect tach to green HI-6 wire. MSD-6: connect tach to MSD-6 tach terminal. Other CD units:

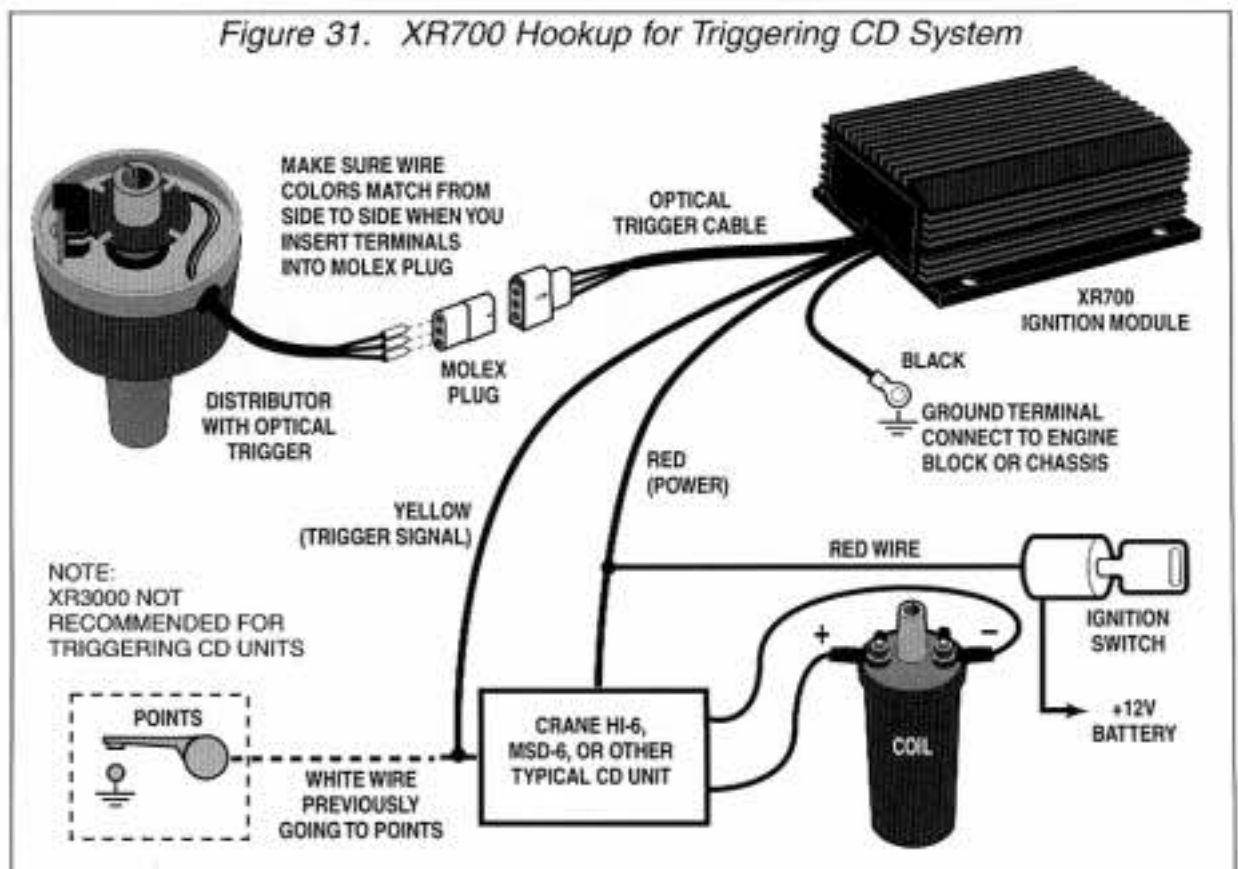

unless instructed otherwise, connect tach wire to XR700 yellow wire

7. Insert the three terminals on the end of the cable from the optical trigger assembly into the Molex plug supplied with the installation kit. Make sure that the individual wire colors match from side to side. Use a small screwdriver to push the terminals all the way into the Molex plug. Then connect it to the mating Molex plug on the cable from the module. If you must remove a terminal, see Figure 22 and use the provided extraction tool.
8. Continue with the standard installation instructions starting at the Optical Trigger Adjustment Procedure section on page 13.

TROUBLESHOOTING CD TRIGGER APPLICATIONS

1. Pull the high voltage coil wire out of the distributor and connect it to a KD Tools HEI test plug. Make sure the test plug is clipped to ground. Crank the engine. If sparks fire, the problem is in the secondary system.

2. Check for +12 volts on XR700 red wire with ignition key turned on. If +12 volts is not present, trace wires to ignition switch and re-establish connection.
3. Try a different ground connection point on the engine block or metal chassis and repeat test.
4. Disconnect XR700 yellow trigger wire from CD unit. Connect a test light between the battery positive terminal and XR700 yellow wire. Crank the engine. If the light flashes on and off, the optical trigger and module are okay, but CD unit or coil may have failed.
5. Reconnect yellow trigger wire. Then check optical trigger as explained in the standard XR700 troubleshooting section on page 15.
6. For rough or intermittent operation, follow the steps given in the standard XR700 Troubleshooting section on page 14.

USE OF TACH ADAPTER TO OVER- COME ERRATIC TACH INDICATION

Some applications, such as Ferrari and Porsche, may require the use of Crane tach adapter part number 8-2050 to overcome an erratic tach indication. While the 8-2050 is primarily sold as a motorcycle tach adapter, the hookup shown in Figure 32 should solve most tach problems. The tach adapter can be ordered directly from Crane.

